

# **MLCS BOX JOINT TEMPLATES**

## **FOR PINS AND TAILS**

### **HALF BLIND DOVETAIL JIG**



**COMPLETE INSTRUCTION  
MANUAL & REFERENCE GUIDE**



**PLEASE READ BEFORE USING YOUR  
TEMPLATE**

# WORKING WITH BOX JOINTS

Box joints (AKA "Finger Joints") provide a simple, yet equally effective, alternative to dovetail joinery. In particular, they serve well for applications where utility is of greater consideration than a decorative appearance.

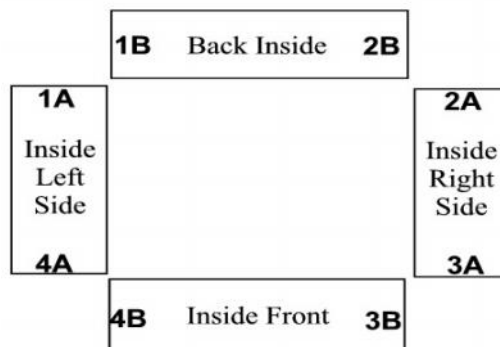
## Getting Started

- ✓ Only run Box Joints on the front of your jig.
- ✓ You must clamp and rout each end of the stock individually.
- ✓ You must use a backer board when cutting box joint. This extra board, clamped under the top bar of the jig, supports the router, reduces tear out, and prevents accidental cuts into the body of the jig. Your backer board should be as wide as your stock and 1/4" or more thicker.
- ✓ Always test cut on scrap wood before starting your project.
- 1/4" Box Templates are for use with 3/8" OD Guide Bushing and 1/4" diameter straight bit.
- 1/2" Box Templates are for use with 5/8" OD Guide Bushing and 1/2" diameter straight bit.

## Preparing Your Stock

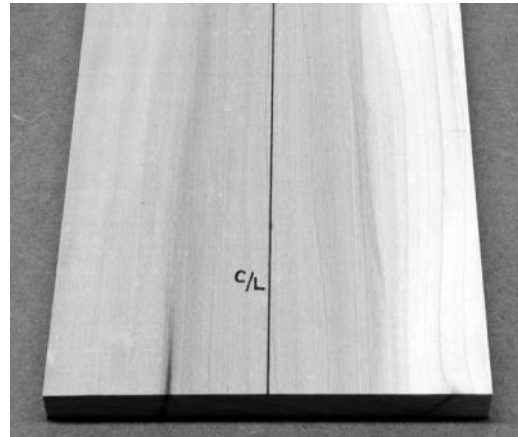
- Though simple to make, precise stock preparation and set-up is essential to successful box joint creation.
- 1) All stock pieces should be cut precisely to the required dimensions of your finished drawer or box.
    - ✓ 1/4" Box Joint Template is compatible with stock thickness of 1/4" to 1/2".
    - ✓ 1/2" Box Joint Template is compatible with stock thickness of 1/4" to 1".
  - 2) Arrange your wood and label as shown in the diagram below.

*Proper Layout for Drawers or Boxes*



- 3) You will also need to cut 2 pieces of scrap stock to the exact dimensions of your box or drawer pieces to use as set-up boards. Precisely calculate and mark the center of the stock (marked **C/L in figures**) on the edge guide set-up board. **(Figure 1)** Save the second piece of stock for use in Step #9 of the Set-Up Instructions.

- Width of stock to be routed will influence the exact layout, so this will change from project to project. **HOWEVER**, if you plan to repeat the same project in the future, you should keep set-up boards for repeated use.



**Figure 1**

## **Set-Up**

This set-up will provide a joint with the same size fingers on both edges of your joint.

- 1) Loosely attach the edge guides to the jig. Choose the appropriate edge guides for your width of stock to allow proper positioning. (Most often, #2 edge guides will be used). Temporarily align these as far to the outside of the jig as they will go.
- 2) Connect the Box Joint Template, positioning the backer board beneath the top clamp. Twist to tighten the brass nuts for the template **ONLY**--Do not tighten the top clamp bar at this point.
- 3) To align the left edge guide, position the edge guide set-up board under the front clamping bar and to the left side of the jig.
- 4) Adjust the edge guide set-up board to the right so that the center line (C/L) marked on the set-up board is perfectly centered in the next possible slot on the template. Secure the set-up board under the front clamping bar by tightening the front knobs. **(Figure 2)**



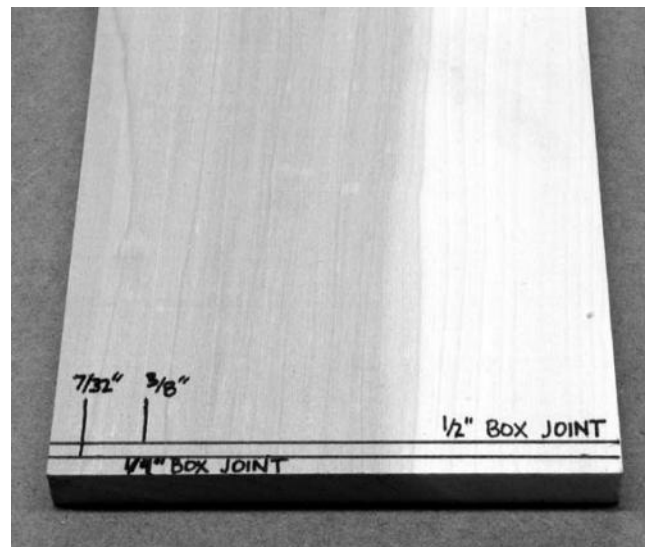
**Figure 2**

- *If your stock is 1/2" or less thick, use nylon spacers on the front clamping knobs so the knobs will not come in contact with the template bracket studs when tightened. In most cases, the spacers for the top clamping bar can be used here.*
- 5) Remove the template and adjust the edge guide so that it touches the set-up board clamped under the front clamp bar. Secure the edge guide in place by tightening the edge guide screw.
  - 6) To align the right edge guide, position the edge guide set-up board under the front clamping bar and to the right side of the jig.
  - 7) Adjust the edge guide set-up board to the left so that the center line (C/L) marked on the set-up board is perfectly centered under the next possible finger on the template. Secure the set-up board under the front clamping bar by tightening the front knobs. **(Figure 3)**



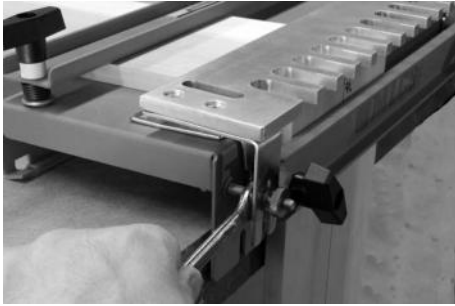
**Figure 3**

- 8) Remove the template and adjust the edge guide so that it touches the set-up board clamped under the front clamp bar. Secure the edge guide in place by tightening the edge guide screw.
- 9) After positioning the edge guides properly, you will need another set-up board for fixing the template position. For 1/2" box joints, mark the setting line 3/8" from the edge of the board. For 1/4" box joints, mark the line 7/32" from the edge. **(Figure 4)**
- 10) Position scrap stock beneath the front clamp bar.
- 11) Position the set-up board underneath the top clamp, tight against the scrap stock, and place the template right on top.

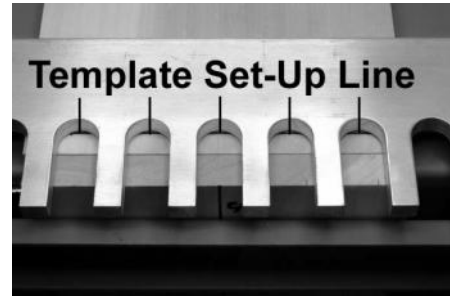


**Figure 4**

12) Loosen the brass knob. Then rotate the lock nuts with a 10mm wrench (**Figure 5**) until the template set-up line on the set-up board is aligned with the back of the template slots (**Figure 6**). ( $3/8"$  for  $1/2"$  Box Joints and  $7/32"$  for  $1/4"$  Box Joints)



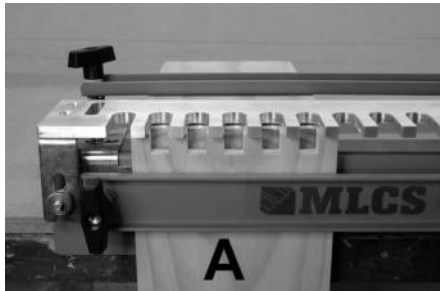
**Figure 5**



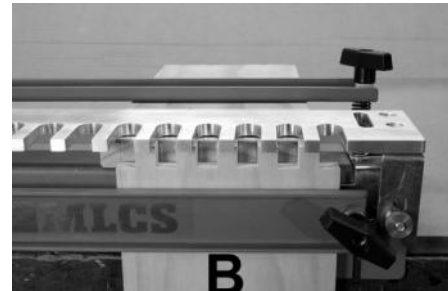
**Figure 6**

## **ROUTING BOX JOINTS**

- 1) Set your depth of cut so that your bit extends above the router base by a height of  $1/4"$  plus the thickness of your stock. (*Example: If your drawer/box uses  $3/4"$  stock, the bit should stick out  $1"$  above the router base.*)
- 2) Alternately, cut the joint a slight bit deeper (an extra  $1/32"$  or less) and you can sand the joint down after assembling.
- 3) All stock marked "A" should be cut using the left side of the jig (**Figure 7**). All stock marked "B" should be cut on the right side of the jig (**Figure 8**). This is necessary so the joints will match properly.

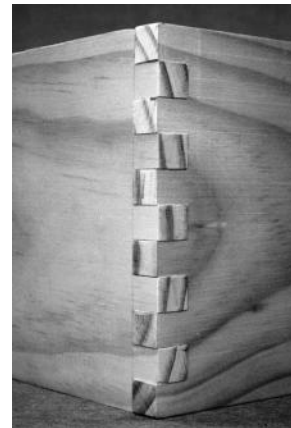


**Figure 7**



**Figure 8**

- 4) Rout from left to right, tracing along each finger.
- 5) Repeat Steps 1-4 for each of your 4 sides.
- 6) Check your sides for a proper fit by assembling them. If they are not fitting properly, you may need to readjust your edge guides.



## **MAKING IT ALL FIT: QUICK TIPS for RESOLVING COMMON BOX JOINT ISSUES**

### **Offset Sides:**

- ✓ Re-calculate the position of the edge guides.
- ✓ Double-check the center line marking on your set-up board.
- ✓ Check your stock for consistent width.

### **Joint Fingers Are Too Long:**

- ✓ Bit is too high. Lower your bit height.

### **Joint Fingers Are Too Short:**

- ✓ Bit is too low. Raise your bit height.

### **Gaps Between Fingers:**

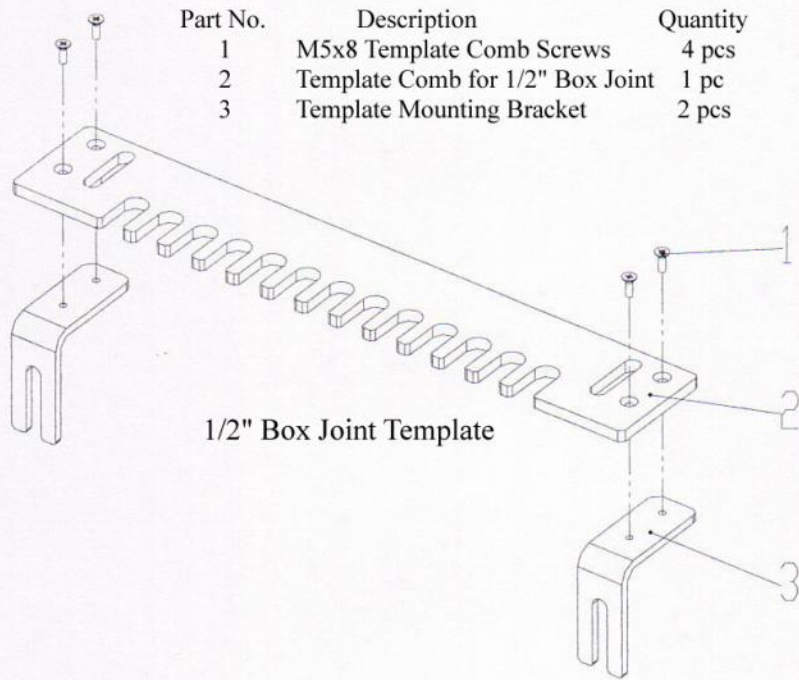
- ✓ Check your router bit. It may be worn or the wrong size.
- ✓ Check template guide bushing for proper size and wear.
- ✓ Check router bearings for wear.

### **Thick Stock Won't Fit Under the Front Clamp Bar:**

- ✓ Take out the spacers.

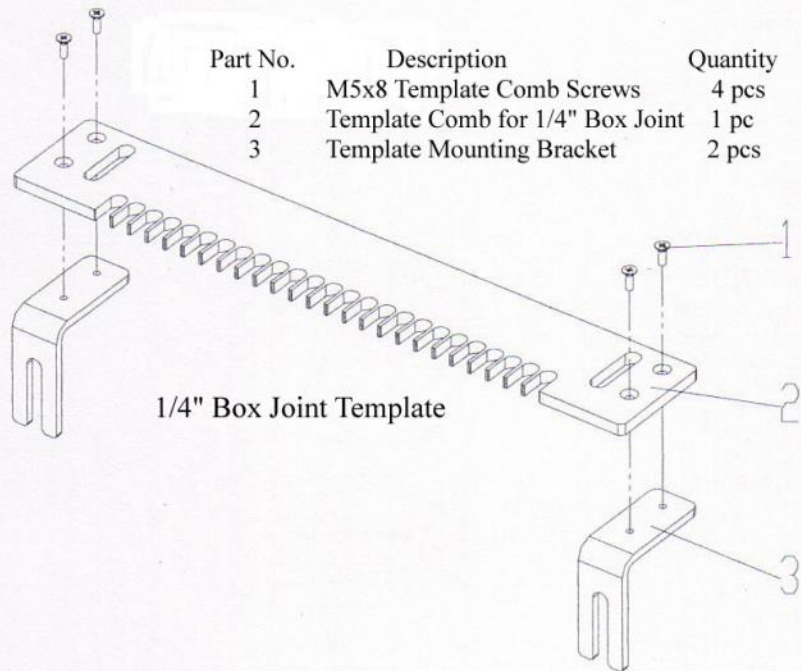
### **Thin Stock Won't Lock Under the Front Clamp Bar:**

- ✓ Add the additional spacers.



Part No.	Description	Quantity
1	M5x8 Template Comb Screws	4 pcs
2	Template Comb for 1/2" Box Joint	1 pc
3	Template Mounting Bracket	2 pcs

1/2" Box Joint Template



Part No.	Description	Quantity
1	M5x8 Template Comb Screws	4 pcs
2	Template Comb for 1/4" Box Joint	1 pc
3	Template Mounting Bracket	2 pcs

1/4" Box Joint Template